

IR Ingersoll Rand.

AIR TOOLS & Accessories 2011

3/8" Air Impactool

The best
power-to-weight
ratio in its class



\$244.78

#2115TiMAX

- 300 ft.-lbs. torque
- Enhanced power settings
- Free two-year limited warranty with tool registration

1/2" Air Impact Wrench



- The best power-to-weight in its class
- 780 ft.-lbs. torque
- Easy to use forward/reverse push buttons
- Power control dial

#2135Ti-2MAX
With 2" Anvil
Weighs Only 4.4 lbs.

\$288.01

#2135TiMAX
Weighs Only 3.95 lbs.

\$284.51

1/2" Super Duty



#231C

\$143.00

- Pressure-fed lubrication system
- Adjustable power regulator
- Easy to service 2-piece construction
- Variable-speed

3/4" Super Duty



#261

\$433.48

- Jumbo hammer mechanism
- Up to 1,100 ft.-lbs. of torque
- Compact, only 7-5/8" long
- Handle exhaust
- Trouble-free, longer performance aided by the pressure-fed lube system

3/4" Impactool



#259

\$320.73

- Two power settings in both forward & reverse
- Up to 1,050 ft.-lbs. of torque
- Variable speed trigger offers impressive control
- Silenced exhaust reduces tool noise while in use

3/4" Ultra Duty

- 1200 ft.-lbs. torque
- Weighs just 7 lbs./Only 8.2" long
- TwinHammer Plus™ mechanism for 30% greater durability
- Contoured professional touch trigger and ergonomically designed handle for increased comfort



#2141

\$513.51

1/2" Super Duty

- Powerful, with smooth, balanced blows
- Pressure-fed lubrication system automatically greases the impact mechanism
- More horsepower for extra torque output
- Non-biased 500 ft. lb. in forward & reverse



#244A



\$225.50

Bring out the "Big Gun" for heavy truck work

1/2" Heavy Duty Air Impact

- Full-stroke tease throttle
- 600 ft.-lbs. maximum torque
- Multi-position power management
- Superior ergonomics in a lightweight package



#2130

\$176.29

IR power & durability at an exceptional value

Economical

1/2" Extended Anvil Air Impact

- Handle exhaust directs air away from user
- Adjustable power regulation
- Pressure-fed lube system for trouble-free performance & long life
- Adjustable power regulation



#231HA-2

\$148.99



The top choice in tire service centers



3/4" Super Duty

- Jumbo hammer mechanism
- Up to 1,000 ft.-lbs. of torque
- Pressure-fed lube system for trouble-free performance & long life
- Compact size - 8.8" long with high output



#261-3

\$467.94



3/4" Super Duty

- Jumbo hammer mechanism
- Up to 1,000 ft.-lbs. of torque
- Pressure-fed lube system for trouble-free performance & long life
- 6" extended anvil to reach lug nuts in deep truck wells



#261-6

\$473.49

1" Titanium Duty



- Maximum torque of 1,650 ft.-lb.
- Weighs 15.5 lb.
- Extended robust anvil bushing provides long life under heavy shop usage
- Designed specifically for tire changing



#2190Ti-6

\$713.89



1" Super Duty Air Impacttools

- Fast-torque™ delivers 1,000 ft.-lb. in 2 seconds
- 1,475 ft.-lbs. maximum torque
- Improved feather touch trigger
- High efficiency, 6-vane motor
- Combines exceptional power, control & durability

Enhanced durability for longer life

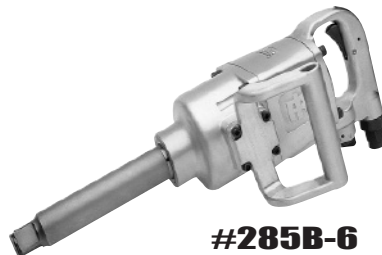

#285B-6
20.1" Length
\$449⁰⁰

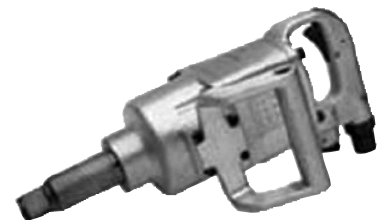

#285B
13.2" Length
\$527⁹⁹

3/8" Heavy Duty Air Ratchet Wrench



- 54 ft.-lb. maximum torque
- 360° adjustable exhaust directs air away from the operator & the work
- Variable speed lever-style throttle

Multi-Purpose Air Angle Die Grinder



- Compact, lightweight, & easy to handle
- Self-locking throttle
- Precision-machined gearing delivers maximum power transfer

Mini Air Die Grinder

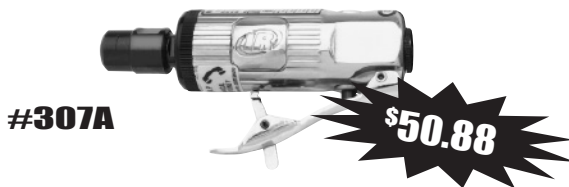

- Standard 1/4" collet for all types of accessories
- Safety lever prevents accidental starts
- Front exhaust helps keep work surface clean

IR Air Angle Die Grinder

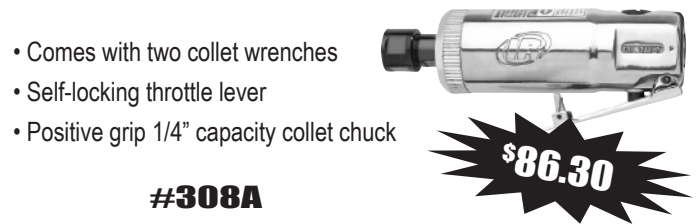

- Comes with two collet wrenches
- Self-locking throttle lever
- Positive grip 1/4" capacity collet chuck

Dual-Action Quiet Air Sander 6" Pad



- Economical
- Balanced ball bearing construction
- Adjustable built-in regulator for positive speed control
- Low vibration

Super Duty Air Hammer

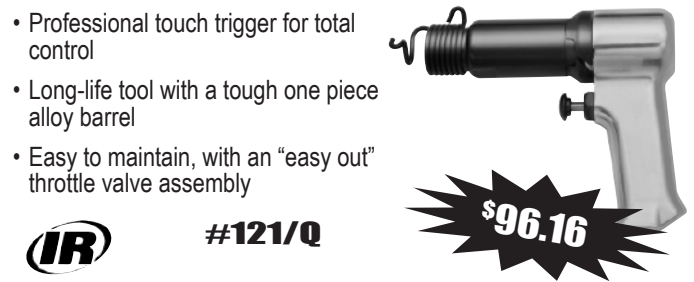

- Professional touch trigger for total control
- Long-life tool with a tough one piece alloy barrel
- Easy to maintain, with an "easy out" throttle valve assembly

Low Speed Air Tire Buffer

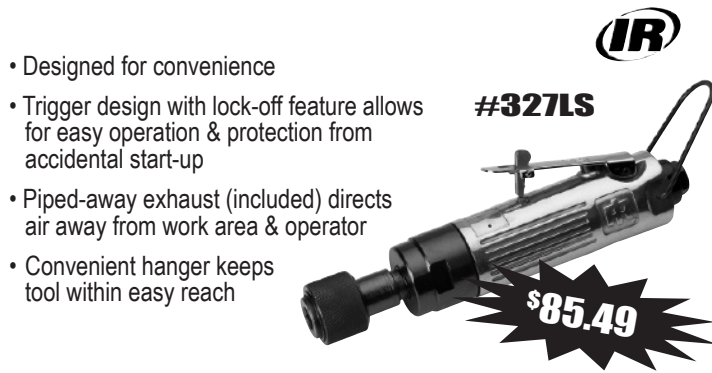

- Designed for convenience
- Trigger design with lock-off feature allows for easy operation & protection from accidental start-up
- Piped-away exhaust (included) directs air away from work area & operator
- Convenient hanger keeps tool within easy reach

#121K6
\$98.99

Comes with 5 piece
Chisel Kit (# 116-K5)



5 Piece Chisel Kit

Kit Includes:

- Edging Tool
- Tail Pipe Cutter
- Straight Chisel
- Cutting Chisel
- Punch



#116-K5
\$18.99 **IR**

Tool Bag #TB2

- Constructed of double-lined ballistic nylon for durability
- Padded shoulder strap & handle for increased comfort
- Spacious inside & outside pockets for storing accessories



\$29.40

Air Reciprocating Saw

#429



\$94.31

- Comes with six high-speed steel cutting blades & two hex wrenches
- Cuts flat and curved surfaces
- Durable, long life tool



Surface Conditioning Kit

\$103.56



Kit Includes:

Description	Qty.
IR301 Angle Die Grinder	1
3" Course 3M Roloc™ Conditioning Pads	2
3" Medium 3M Roloc™ Conditioning Pads	2
Disc Holder	1
Plastic Case	1



#301-32MK

Composite Straight Die Grinder Kit with Carbide Burrs

Kit Includes:

Description	Qty.
3108 Die Grinder	1
1/2" Cylindrical Bit Super Cut Burr	1
3/8" Cylindrical Bit Super Cut Burr	1
3/8" Ball Shaped Super Cut Burr	1
1/2" Tree Shaped Super Cut Burr	1



#3108K

\$106.64



Needle Scaler

#125

- 19 needles
- Each needle measures 1/8"
- 4,600 blows per minute at free speed



\$163.35



Cut-Off Tool

#326

- Provides 18,000 rpm for fast cutting
- Large hooked locking throttle lever provides user comfort & safety
- Steel shield deflects debris away from operator



\$59.89

Composite Angle Die Grinder Surface Prep Kit

#3102K



Kit Includes:

Description	Qty.
3102 Composite Angle Die Grinder	1
2" Quick Change Backing Pad	1
3" Quick Change Backing Pad	1
2" Surface Prep Disc - Med, Red	2
2" Surface Prep Disc - Course, Brown	2
3" Surface Prep Disc - Med, Red	2
3" Surface Prep Disc - Course, Brown	2
2" Ceramic Oxide Sanding Disc - 36 Grit	2
2" Ceramic Oxide Sanding Disc - 50 Grit	2
3" Ceramic Oxide Sanding Disc - 36 Grit	2
3" Ceramic Oxide Sanding Disc - 50 Grit	2



\$155.95

High Intensity LED Task Light



- Works with all IQ^v batteries
- 160° pivoting, low-profile head provides lighting versatility
- High-quality 4-watt LED bulb lasts up to 50,000 hours



#TL10

\$72.12

3/8" Square Drive Impactool

- 150 ft.-lbs. max reverse torque
- Less than 4.7 lbs. with the lithium ion battery
- All metal hammercase & housing ring for added durability

#W150

\$119.58

Battery & charger sold separately.



1/2" Cordless Impactool



- Pound-for-pound, the most powerful cordless impactool in the world
- 360 ft.-lbs. maximum reverse torque
- Lightweight - only 6.2 lb. with lithium-ion battery

#W360

\$189.85

Battery & charger sold separately.

Light Weight



1/2" Impactool 19.2 Volt Lithium-ion Starter Pack

#W360-LSP



\$355.08

Pack Includes:

- (1) W360 1/2" drive Impactool
- (1) BL192 19.2 Volt lithium battery
- (1) IQ^v charger
- Ingersoll Rand tool bag included

3/8" Impactool 14.4 Volt Lithium-ion Starter Pack

#W150-LSP



\$277.16

Pack Includes:

- (1) W160 3/8" drive Impactool
- (1) BL144 14.4 Volt lithium battery
- (1) IQ^v charger
- Ingersoll Rand tool bag included

Lithium-ion Batteries



- Industry leading lithium-ion cell technology blows competition away with over 1,000 real recharges
- Requires only one cell to match the power in four nickel-cadmium/nickel-metal hydride cells
- Patented twist-to-lock technology firmly holds battery in place



BL144

BL144 14.4 Volt Battery **\$108.25**

BL192 19.2 Volt Battery **\$123.62**

Battery Charger

#BC10

- Allows the charger to charge all IQ^v batteries including all voltages of nickel-cadmium and lithium-ion
- Fully charges most batteries in less than 45 minutes
- Renew feature deep-cycle charges nickel-cadmium batteries - eliminating memory effect, restoring to like-new capacity



\$74.17

CHAMPION®

A Gardner Denver Product

Advantage VR7F-8 Compressor

- Wired for 230V single phase
- HD 2-stage splash-lubricated pump
- 7.5HP motor
- 80 Gallon vertical Tank
- 33" L x 24" W x 77" H
- Magnetic starter
- Air-filled aftercooler
- Low-oil level monitor
- Automatic tank drain
- Vibration isolator pads
- Warranty: Compressor - 1 Year/Electric Motor 5 Year

23.5 CFM @ 175 PSI

#VR7F-8

\$2482⁹⁵



IR Ingersoll Rand

Tool Lube & Lube Kits



- 10P** Air Tool Lube - 1 Pint..... **\$5⁹⁵**
- 10Z4** Air Tool Lube - 4 Oz. **\$3¹⁵**
- 10G** 115 Grease - 1 Gallon **\$27⁶⁵**
- 38436739** Small Recipricating Lubricant - 1 Liter..... **\$13⁴⁴**

Shop Air Hi-Miler

Blue Air Hose

GOOD YEAR

Premium Air Hose

- GY65133 3/8" x 25 ft.
- GY65137 3/8" x 50 ft.
- GY65138 1/2" x 50 ft.



F5™ Ultra Flexible Air Hose

- Requires 20% less force to bend than competitive hose, and up to 50% less than comparable PVC and rubber air hose.
- Up to 45% lighter than comparable PVC and rubber air hose
- F5 provides all weather performance, with a temperature rating of -40°F to 158°F
- Veyance testing shows F5 matches industry-leading levels of durability performance while also providing a non-marking surface

GOOD YEAR

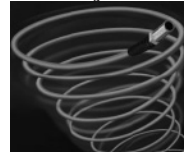

Part No.	Description	Fitting
65178	3/8" x 25	MxM 1/4 NPT
65179	3/8" x 50	MxM 1/4 NPT
65182	1/2" x 50	MxM 1/2 NPT

- Impact Sockets
- Budd Wheel Sockets
- Deep Socket Sets
- Metric Socket Sets
- Impact Chisels
- Drive Wheel Service Sets
- Universal Impact Sockets
- And Much More!



Grey Pneumatic Corp.



SEE OUR FULL LINE GREY PNEUMATIC CATALOG

CATALOG NUMBER **37**

April 2011 (10IRProductGuide)



Iowa	Des Moines 1436 E. Ovid (515) 265-1491 Fax (515) 265-4120 Parts Fax (800) 314-4329 (800) 888-0248	Cedar Rapids 200 50th Ave. S.W. (319) 365-4453 Fax (319) 365-6327 (800) 332-5435 Fax (877) 706-6085	Clear Lake 840 Hwy. 18 W. (641) 357-7101 Fax (641) 357-8190 (800) 397-5630 Fax (800) 548-9674	Missouri	Kansas City 5801 E. Front St. (816) 471-1552 Fax (816) 471-0813 (800) 821-7402
	Davenport 8502 Northwest Blvd. (563) 322-2671 Fax (563) 322-5940 (800) 553-1886	Sioux City 1819 E. 4 th St. (712) 252-7969 Fax (712) 252-6149 (800) 943-3534	Grandview 14817 So. 71 Hwy. (816) 318-9111 Fax (816) 318-9114 Toll Free (866) 318-9111		