

Gold Seal® Actuators

Durability and Reliability
Mile After Mile

Available Welded Clevis Push Rod

Fits Haldex, Meritor & Gunite ABS's
Made to fit Freightliner (long stroke) and
Volvo (standard & long stroke)

- Reduces Wear & Loose Clevis Issues
- Easier Installation
- No cutting - Always Right

GC3030CW
GC3030LCW

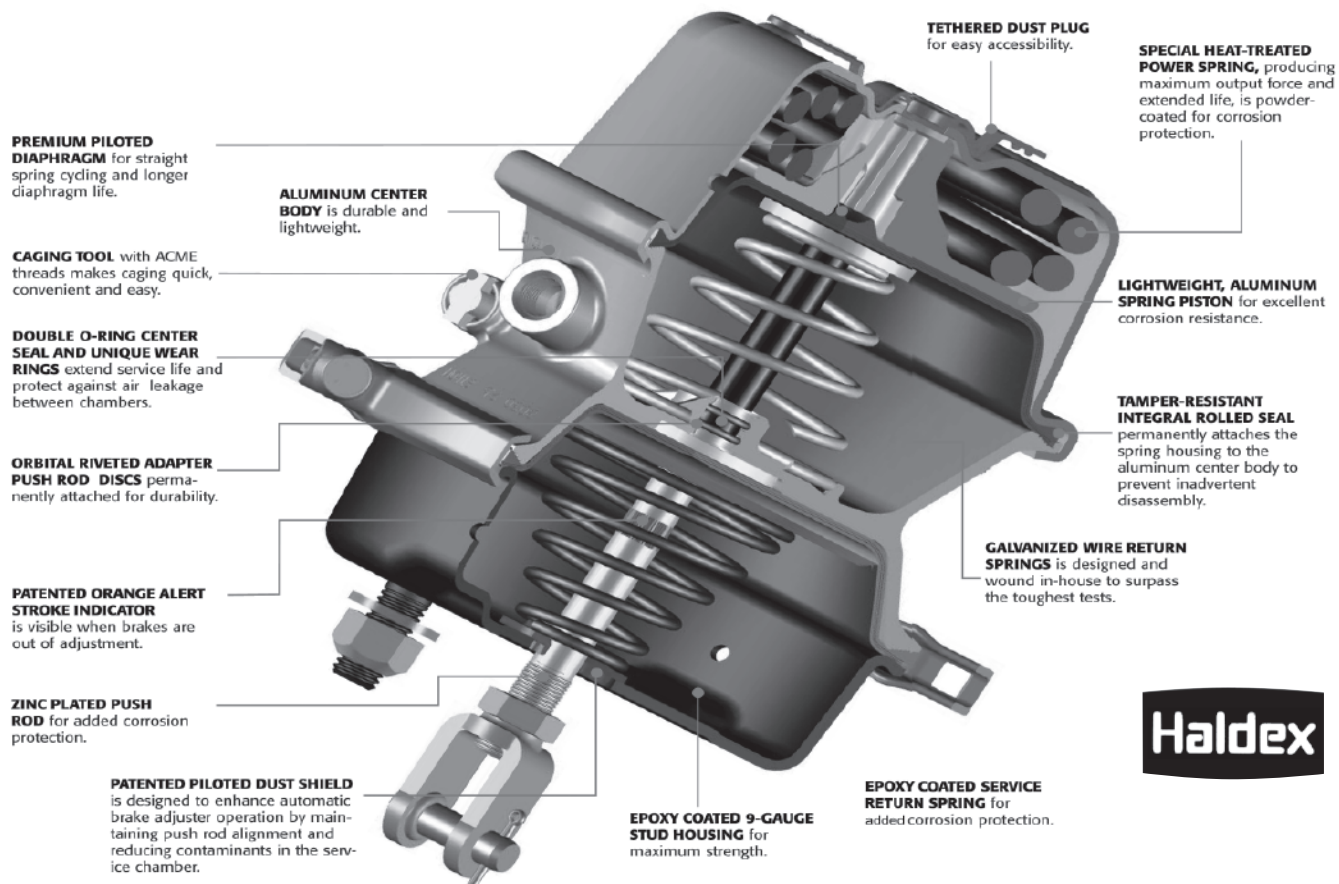

Save Time & Ensure Accuracy with Pre-Cut Push Rods

		Push Rod				Push Rod	
		Length	Stroke			Length	Stroke
GC3030S3P40	Fits most trucks/tractors w/clevis	1.8"	2.5"	GC3030CW	With welded Clevis	1"	2.5"
GC3030S2P40	Most Trailers w/Clevis	5.70"	2.5"	GC3030LCW	With welded Clevis	1"	3"
GC3030S4P40	Intraax® w/o Clevis	9.90"	2.5"	GC3030R	Hendrickson w/Clevis	14"	2.5"
				GC3030	Standard w/Clevis	10"	2.5"

Gold Seal Chambers

P/N	Type	Stroke	Description	P/N	Type	Stroke	Description
GC2024	20/24	2.25	Complete	GP2424	24	2.25	Piggyback
GC2424	24	2.25	Complete	GP2424L	24	2.50	Piggyback - Long Stroke
GC2424L	24	2.5"	Comp. Long Stroke	GP2430	24/30	2.25	Piggyback
GC2430L	24/30	2.50	Comp. - Long Stroke	GP2430L	24/30	2.50	Piggyback - Long Stroke
GC2430	24/30	2.25	Complete	GP2430XL	24/30	3	Piggyback - XL Stroke
GC2430XL	24/30	3"	Comp. - XL Stroke	GP3030	30	2.50	Piggyback
GC3030	30	2.50"	Complete	GP3030K	30	2.50	Piggyback - Kit
GC3030L	30	3"	Comp. - Long Stroke	GP3030L	30/30	3"	Piggyback - Long Stroke
GC3030R	30	2.50	Complete	GP3030LK	30	3	Piggyback - Long Stroke Kit
GC3036	30/36	2.50	Complete	GP3036	30/36	2.50	Piggyback
GC3636	36	3	Complete	GP3636	36/36	3	Piggyback
GP2024	20/24	2.25	Piggyback				

Life Seal[®] Actuators

ZINC-PLATED STEEL CHAMBER isolates the power spring preventing all contaminants from entering the spring chamber. No vent holes, no air filters, no caging tool plugs and no external breather tubes.

PUSH ROD HOUSING TUBE maintains coil alignment and reduces coil stress and coil clash by guiding the spring piston and power spring on a straight path.

INTERNAL VALVE allows trapped air inside the spring chamber during the caging process to escape through the vehicle air system.

PATENTED PILOTING DUST SHIELD is designed to enhance automatic brake adjuster operation by maintaining push rod alignment and reducing contaminants in the service chamber.

EPOXY COATED 9-GAUGE STUD HOUSING for maximum strength.

INTEGRAL CAGING TOOL with grade 8 ACME threads makes caging quick, convenient and easy.

SPECIAL HEAT-TREATED POWER SPRING, producing maximum output force and extended life, is powder-coated for extra protection.

PATENTED ALUMINUM FORM FIT SPRING PISTON reduces overall actuator length.

CENTER BODY SEAL maintains a positive seal with superior guiding and alignment.

PATENTED ORANGE ALERT STROKE INDICATOR is visible when brakes are out of adjustment.

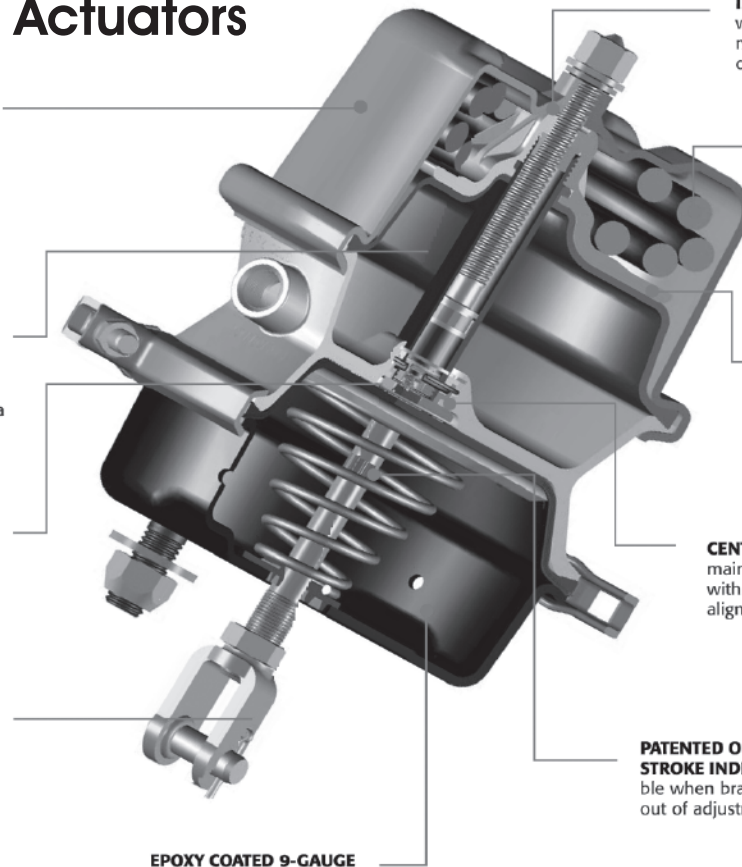

Isolated Chamber Prevents Spring Fracture

Compression spring fracture is the major cause of all spring brake failures. Water, salt, oil and other contaminants attack and weaken the spring causing corrosion and ultimately, failure. Since the Life Seal chamber is completely sealed, contaminants cannot reach the power spring. The spring housing does not contain vent holes, external breather tubes, cage tool plugs or filters so the spring is isolated from the external environment. A special internal valve allows air to escape through the vehicles' air system instead of through the housing.

Life Seal Maximizes Output Force

Most new spring rakes meet a minimum required output force. The ability for that spring to maintain output force is lost over time. Through technological innovation, Life Seal is the only actuator to maximize output force over an extended period. A unique patented power spring maintains high output force while increasing strength. The center tube guides the form-fit pressure plate, which stabilizes the spring coil through the full range of travel. This prevents contact with the spring housing and dramatically reduces coil clash.

Delivering Reliability, Long Life and Value

P/N	Type	Stroke	Description
LC3030	30/30	2.5"	Complete
LC3030L	30/30	3"	Long Stroke Complete
LP3030	30	2.5"	Piggyback
LP3030K	30/30	2.5"	Piggyback Kit
LP3030LK	30/30	3"	Long Stroke Piggyback Kit



February 2011 (GoldSeal_10)



Iowa	Des Moines 1436 E. Ovid (515) 265-1491 Fax (515) 265-4120 Parts Fax (800) 314-4329 (800) 888-0248	Cedar Rapids 200 50th Ave. S.W. (319) 365-4453 Fax (319) 365-6327 (800) 332-5435 Fax (877) 706-6085	Clear Lake 840 Hwy. 18 W. (641) 357-7101 Fax (641) 357-8190 (800) 397-5630 Fax (800) 548-9674	Missouri	Kansas City 5801 Front St. (816) 471-1552 Fax (816) 471-0813 (800) 821-7402
	Davenport 8502 Northwest Blvd. (563) 322-2671 Fax (563) 322-5940 (800) 553-1886	Sioux City 1819 E. 4 th St. (712) 252-7969 Fax (712) 252-6149 (800) 943-3534	Grandview 14817 So. 71 Hwy. (816) 318-9111 Fax (816) 318-9114 Toll Free (866) 318-9111		